

# Catapult

Author: Future Scientists and Engineers of America (FSEA)  
 Date Created: 1997  
 Subject: Engineering, Physics  
 Level: 4<sup>th</sup> grade and up  
 Standards: *New York State- Elementary Science (www.emsc.nysed.gov/ciai/)*  
                   Standard 1- Analysis, Inquiry and Design  
                   Standard 4.5- The Energy and matter interact through  
                                   forces that result in changes in motion  
                   Standard 7- Interdisciplinary Problem Solving  
**Schedule: Two or three 60-minute class periods**

## Objectives:

Give students an experience in engineering while teaching principles of physics. Introduce students to the scientific processes of experimentation and trial and error.

## Students will:

- Be introduced to the history of catapults and the theory of how they work.
- Learn physics vocabulary terms.
- Assemble a basic catapult from the kit provided for them.
- Observe the changes in the catapult's performance after adjustments.
- Record their catapult's performance.
- Compete to test their team catapult's accuracy at hitting targets at various distances.

## Vocabulary:

|                         |               |
|-------------------------|---------------|
| <b>Potential Energy</b> | <b>Range</b>  |
| <b>Kinetic Energy</b>   | <b>Energy</b> |
| <b>Trajectory</b>       |               |

## Materials:

|   |   |
|---|---|
| <b>For Class:</b><br>Phillips Screwdrivers  | <b>For Each Pair:</b><br>Catapult Kit:<br>4 Rubber bands,<br>Pushpin, 2 Nuts (1/4 x 20), 2 Machine Screws (1/4 x 20 x 4 1/2"), 4 Drywall Screws, 4 Screw Eyes (Open Eye), Hook & Chain, Wood Arm and Base, 2 Pegboard Sides, Whiffle ball |
| <b>For Each Student:</b><br>Activity Sheet 1:<br><i>Catapult Variables</i><br>Activity Sheet 2:<br><i>Catapult Assembly CT-1</i><br>Activity Sheet 3:<br><i>Variable Data Sheet</i><br>Activity Sheet 4:<br><i>Appendix B</i><br>Activity Sheet 5:<br><i>Catapult Science Challenge Questions</i> |   |

## Safety:

Make sure no students are in the catapult's trajectory before triggering it.

## Science Content:

Over 2000 years ago, the Greeks and Romans did not know about gunpowder, yet were able to hurl projectiles over a large distance using kinetic energy storage devices. Through the years, some modifications were made to increase the accuracy and throwing distance of these machines. The first two types of throwing machines were the catapult and the ballista. The catapult started out as a large cross bow to shoot oversized arrows at an enemy. The ballista was about 10 times larger than a catapult and threw large stones.

The ballista's design consists of two pieces of wood, each fastened at one end to a torsion device rotating about a more or less horizontal axis. The free ends of the wooden pieces are connected together with a rope. The projectile to be thrown is held by the connecting rope used as a sling.

When most people think of the catapult, they are actually thinking about an onager. The strange name is derived from a wild donkey kicking with its hind legs. The onager (or gone, mangonel, or nag) was typically a single spar held in a more or less vertical position by a torsion device rotating around a horizontal axis. The projectile was located in either a pocket at the top end of the spar or in an attached sling.

The choice of the Middle Ages was a trebuchet. This device used gravity instead of torsion springs to provide propulsion energy. The theory is simple: put a large weight at the short end of a lever arm and put the projectile in some kind of basket at the other end of the lever. The velocity of the projectile can become quite large when the ratio of the lengths of the lever arms is great. Incidentally, the trebuchet was also used as a punishment device called the ducking stool. People were placed in a seat at the long end and successively ducked into a pool of water.

The catapult is still in use today, although radically different from those used in history. The modern catapult is used to launch aircraft from the deck of an aircraft carrier. The aircraft carrier catapult uses steam as a source of energy to push a piston along a linear track in the aircraft carrier's deck. The piston pushes the aircraft and accelerates the plane up to flying speed in a very short distance. The same kind of mechanism can be found at Knott's Berry Farm, where it propels the Montezuma's Revenge roller coaster ride.



The following information is for the mentor/teacher to assist in conducting the project.

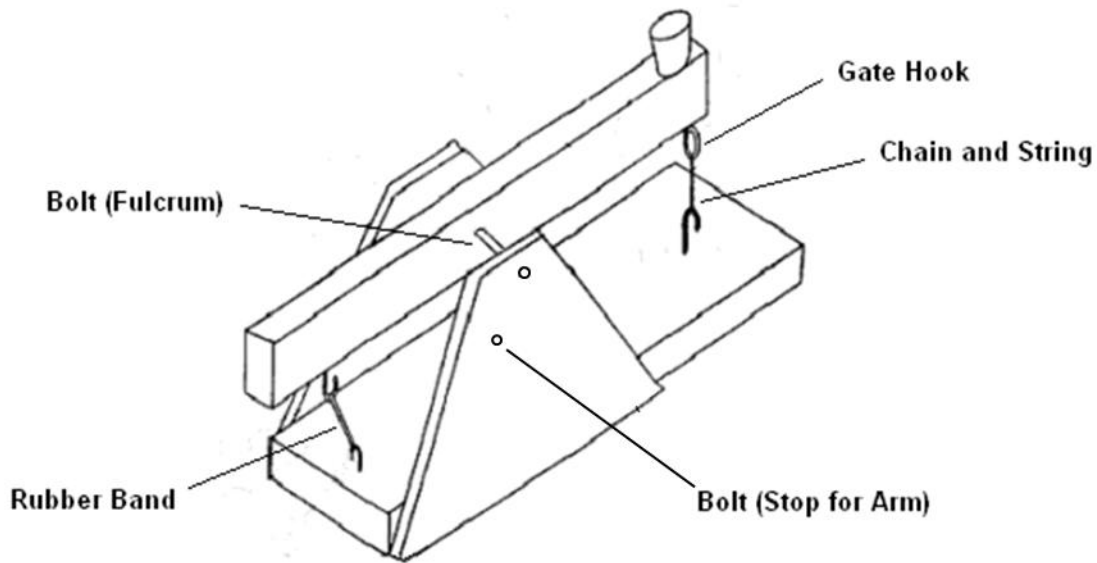

### Assembly Instructions

1. Align the sides with the base and screw in the drywall screws to secure it. These are represented by the x's in the below picture. *Be sure to have the pre-made holes on the base facing up.*

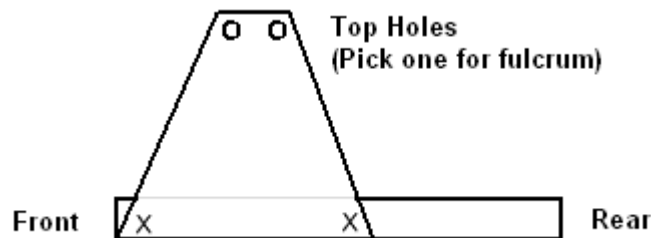

2. Insert the machine screw through one of the top holes of one side, followed by a spacer, the lever arm, another spacer, and then the corresponding hole on the second side. Secure this with a nut, making sure to leave it just loose enough for the arm to swing freely. *Be sure to have the pre-made holes on the lever arm facing down.*
3. Now install the second bolt as a stop for the arm. Make sure it is below the bolt holding the lever arm (fulcrum) and closer to the front. You need not make it terribly tight.

4. Install the hooks at both ends of the base.
5. Install a hook at the front end of the lever arm, and a screw eye at the rear end.

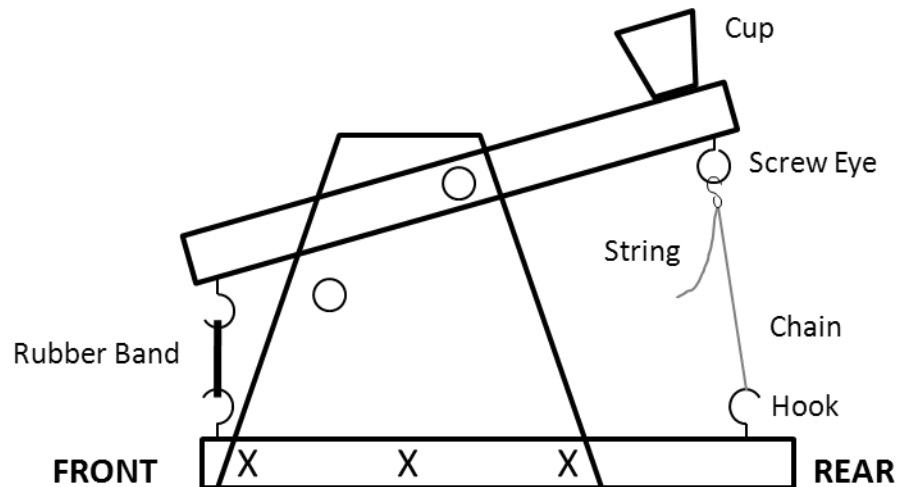

6. Install the hardware in appropriate location (variable). The length of chain with the gate-hook and attached string which acts as a trigger device should always be mounted on the catapult base, with the separate gate-hook eye ONLY being mounted on the catapult arm as shown above. At no time should the jack-chain with the gate-hook attached be flying through the air in an arc at the end of the catapult arm each time the catapult is triggered.
7. Install cup on the lever arm (used to hold the whiffle ball).
8. Install rubber bands and pass out whiffle balls.

**NOTE:** Warn class that the only item to be used in the catapult as a projectile is the whiffle ball. Use of any other material will result in the immediate dismissal of the team.

9. Test and adjust catapults for the competition.

**Preparation:**

1. Photocopy print materials (*Activity Sheets 1-5*) for each student.
2. Students should conduct some library research on the subjects of catapult, trebuchet, and onager before beginning this assignment.
3. Distribute materials evenly to each student pair.
4. Construct target range (see Supplemental Information below).



## **Classroom Procedure:**

### ***Engage (Time: 20 mins)***

Discuss the history and types of catapults outlined in “Science Content” with the students. Discuss physics terminology. Ask the students to engage in a discussion on how to adjust the catapult to vary the distance to which it can throw a projectile (refer to Activity Sheet 1: Catapult Variables) for the list of adjustments which will provide variables to catapult performance. Discuss the adjustments and how they would affect performance.

### ***Explore (Time: Varies)***

Inform students that there will be a competition to test their catapult’s accuracy at hitting targets at various distances. Divide students into groups of two and allow them to begin construction of their catapults. Assist as necessary and use step-by-step guide (refer to Assembly Instructions and Activity Sheet 2). Encourage students to discuss the physics principles and vocabulary they learned as they construct their catapult to increase their understanding.

Set up the target range in the classroom for the competition. Distribute whiffle balls to each student. Tell them they will use these to test their catapults and let them practice hitting the targets. If need be, allow them to adjust the variables on their catapult. Next, discuss the scoring system for the competition (refer to Appendix A3). Explain how teams should take data on their own performance (refer to Appendix A4, Scoring Sheet, and Longest Distance sheet) and let the competition begin!

### ***Explain (Time: 10 mins)***

Discuss with students what did and did not work, have them explain why certain settings worked better than others. Distribute Activity Sheet 5: Catapult Science Challenge Questions as a homework assignment to each student. Allow the students to work on it with their team member. During the next class period, discuss the challenge questions and clear up any misunderstandings the students may have about the concepts they learned.



## Assessment:

The following rubric can be used to assess students during each part of the activity. The term “expectations” here refers to the content, process and attitudinal goals for this activity. Evidence for understanding may be in the form of oral as well as written communication, both with the teacher as well as observed communication with other students. Specifics are listed in the table below.

- 1= exceeds expectations
- 2= meets expectations consistently
- 3= meets expectations occasionally
- 4= not meeting expectations

|   | Engage   | Explore  | Explain   |
|---|--|--|---|
| 1 | Shows leadership in the discussion and offers creative ideas reflecting a good understanding of the physics behind the catapult. | Completes work accurately while providing an explanation for what is observed. Works very well with partner. | Provides an in-depth explanation of findings, making good use of vocabulary terms. Fills out worksheet clearly. |
| 2 | Participates in the brainstorm and shows an understanding of the physics related to the catapult.                                | Completes work accurately and works cooperatively with partner.  | Provides clear explanation of findings. Fills out worksheet clearly.  |
| 3 | Contributes to the brainstorm, but shows little understanding of catapult physics.   | Works cooperatively with partner, but makes some mistakes with the procedure.                                | Provides a limited explanation of findings. Fills out some of the worksheet.                                    |
| 4 | Does not participate in brainstorm. Shows no understanding of catapult physics.  | Has trouble working with partner. Does little to complete the procedure.                                     | Is not clear in explanation of findings. Does not fill out worksheet.   |

## Extension Activities:

- Challenge students to adjust their catapult in order to throw the whiffle ball the longest distance possible.
- Encourage students to think about what other projectiles they could use, how they would perform, and why they would perform this way.
- Challenge questions are listed on the following three pages.



## Catapult (CT1/CT2) Science Challenge

The science challenge questions are designed to relate science content to the FSEA projects. Some of the questions relate specifically to the project. Others, though related, may go well beyond the project. Questions may vary in complexity, but teachers and mentors are encouraged to introduce these concepts to students. The intent is to provide discussion material at the completion of the hands-on project. It is suggested that questions be handed out at the first session and then discussed by the students and facilitators at the final session. It would also be a good idea to give the students the questions with the answers after the discussion.

### 1. Name the various forms of energy involved in the catapult.

Answer: The forms of energy are: potential energy stored in the rubber band or springs, kinetic energy of the arm, kinetic energy of the whiffle ball, friction energy in the catapult mechanism, air friction of the ball as it is moving through the air, increased motion energy of the air molecules as the ball strikes and accelerates them, potential energy of the gravitational field as the ball rises and falls back to earth, compression energy as the ball crashes into the earth, deforming both the ball and the earth, and heat energy as the earth is warmed up a little.

### 2. If one were to use a golf ball instead of a whiffle ball, would the ball go farther, everything else being equal?

Answer: Yes, the light whiffle ball with holes in it has a great deal of air resistance and slows down very quickly. The much heavier golf ball would have much more energy and go much farther. Even a ping-pong ball, which is about the same weight as a whiffle ball, would go farther due to the smooth surface instead of the holes.

### 3. If you were to do the project on the moon, which of the three balls would you expect to go the shortest distance?

Answer: The golf ball, because it is heavier. It would not reach as high a velocity as the other lighter balls and hence wouldn't go as far. Since there is no air on the moon, there would be no air friction for either the whiffle or ping-pong balls.





4. **Using the whiffle ball on earth, if you doubled the rubber bands, so the force would be twice as much, the whiffle ball would leave the cup at about twice the velocity. Would you expect it to go twice as far?**

Answer: No, the friction would be much greater at the higher speed and the distance would be less than two times.

5. **If the ball left the cup going parallel with the ground, would the time in the air be longer with two rubber bands as compared to one?**

Answer: No: The horizontal velocity has nothing to do with the time the ball stays in the air. The force of gravity acts completely independent of the horizontal forces or velocities. The ball begins to fall when it leaves the cup and it falls exactly the same as if it were not moving.

6. **If you didn't have air friction, at what angle with the earth's surface would give the greatest distance?**

Answer: 45 degrees. This gives equal vertical and horizontal velocities, which is well known to give the largest distance. This can easily be proven mathematically, and has long been known by the military artillery folks.

7. **If you tried to fire the catapult exactly the same every time, would you expect the ball to fall in the same place each time, or in some specific pattern that would have specific mathematical meaning?**

Answer: Specific pattern. If you did a large number of shots in exactly the same way, you would find a specific pattern where the majority of the hits are close together and the others scattered about in a "Normal Distribution." The way the distribution is spread depends on the various parameters of the catapult and how well they can be repeated each time.

8. **If the ball leaves the catapult with a velocity  $V$ , what are the vertical and horizontal components?**

Answer: Vertical velocity is  $V \cdot \sin(\theta)$  and the horizontal velocity is  $V \cdot \cos(\theta)$ , where  $\theta$  is the angle between the velocity,  $V$ , and the horizontal.



**9. If there is no air resistance, how high will the ball rise?**

Answer: The ball will act like a falling body with an initial velocity  $V$ . The equation for a falling body is as follows:

$$H = V_v \times T - (1/2) \times g \times T^2$$

Where  $H$  is the height in feet.  $T$  is the time in the air in seconds and  $g$  is the acceleration due to gravity ( $\sim 32.2 \text{ ft/sec}^2$ ) and  $V_v$  is the vertical velocity equal to  $V \times \sin(\theta)$ .

Since both  $H$  and  $T$  are unknown, we need a second equation. This second equation is obtained from the falling body velocity equation:

$$V_t = V_v - g \times T$$

Where  $V_t$  is the velocity at any time.  $V_t$  at the maximum height is zero, thus we have the equation  $V_v = gT$ . Substituting in the equation above we have:

$$H = ((V_v^2)/g) - (1/2) \times g \times (V_v/g)^2$$

$$H = (1/2) \times (V_v^2)/g$$

Example: Assume the velocity is 90 ft/sec and the angle with the horizontal is 30 degrees, what is the height?

$$V_v = 90 \times \sin(30), V_v = 90 \times .5 = 45 \text{ ft/sec}$$

$$H = (1/2) \times (45^2)/32.2 = 31 \text{ feet}$$

**10. How far would the ball go with no air friction in question 9?**

Answer: 109 ft

$$T = 2 \times (V_v/g) = 2 \times (45/32.2) = 2.8 \text{ sec}$$

$$V_h = V \times \cos(\theta) = 90 \times \cos(30) = 90 \times .866 = 78 \text{ ft/sec}$$

$$\text{Distance} = V_h \times T = 78 \times 2.8 = 218 \text{ feet}$$

**11. Show that the maximum distance will be achieved with a 45-degree angle.**

Answer: Combining the above equations, one obtains the range of the ball as a function of the angle with the horizon as follows:

$$H = (2/g) \times (V^2) \times \sin(\theta) \times \cos(\theta)$$

Differentiating  $H$  with respect to  $\theta$  and setting to zero.

$$d(h)/d(\theta) = (2/g) \times (V^2) \times ((-\sin(\theta))^2) + (\cos(\theta))^2$$

Setting this equal to zero makes  $\sin(\theta) = \cos(\theta)$

This is only true if  $\theta$  is 45 degrees.



## Supplemental Information:

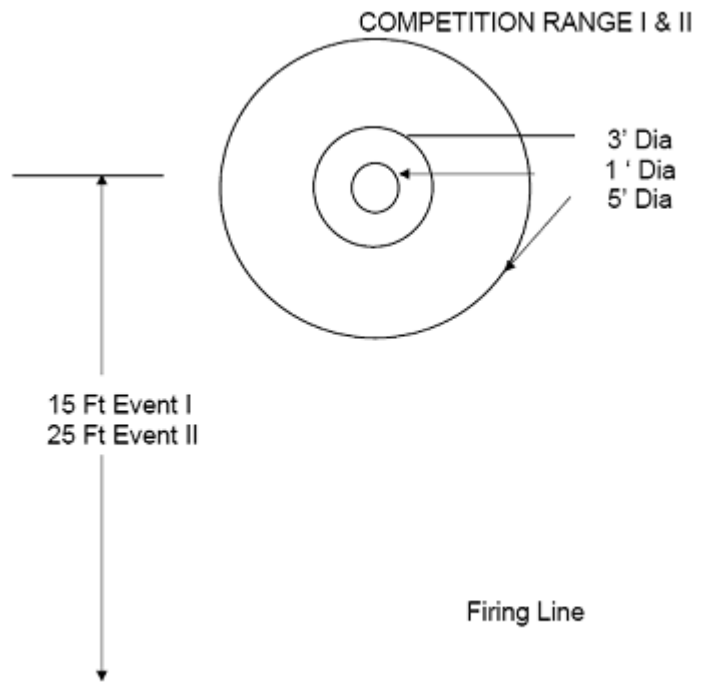

Mentor Note: Target may be constructed as follows: Bulls Eye—use a pie tin taped down. The diameter is approximately 1' and when it hits it “pings”, which increases the thrill of the team able to acquire a direct hit. Middle and Outer rings—use ¼” tubing, string, or rope lengths of 15.7' and 9.4' to form circles. Join ends of tubing with a ¼ wood dowel as a plug. Tape tubes to the floor. Buckets as bullseyes can also make a nice target.

### Scoring

|        | Event 1 | Event 2 |
|--------|---------|---------|
| Inner  | 7       | 15      |
| Middle | 5       | 10      |
| Outer  | 3       | 5       |



TOTAL COMPETITION POINTS

| TEAM | EVENT |     |       | TOTAL |
|------|-------|-----|-------|-------|
|      | One   | Two | Three |       |
|      |       |     |       |       |
|      |       |     |       |       |
|      |       |     |       |       |
|      |       |     |       |       |
|      |       |     |       |       |
|      |       |     |       |       |
|      |       |     |       |       |
|      |       |     |       |       |
|      |       |     |       |       |
|      |       |     |       |       |
|      |       |     |       |       |
|      |       |     |       |       |
|      |       |     |       |       |
|      |       |     |       |       |
|      |       |     |       |       |



**Scoring Sheet:**

SCORING SHEET

|                    | Score |    |    |    |    | Total     |
|--------------------|-------|----|----|----|----|-----------|
| Distance _____ Ft. |       |    |    |    |    |           |
| TEAM               | #1    | #2 | #3 | #4 | #5 | Best of 3 |
|                    |       |    |    |    |    |           |
|                    |       |    |    |    |    |           |
|                    |       |    |    |    |    |           |
|                    |       |    |    |    |    |           |
|                    |       |    |    |    |    |           |
|                    |       |    |    |    |    |           |
|                    |       |    |    |    |    |           |
|                    |       |    |    |    |    |           |
|                    |       |    |    |    |    |           |
|                    |       |    |    |    |    |           |
|                    |       |    |    |    |    |           |
|                    |       |    |    |    |    |           |
|                    |       |    |    |    |    |           |
|                    |       |    |    |    |    |           |
|                    |       |    |    |    |    |           |
|                    |       |    |    |    |    |           |
|                    |       |    |    |    |    |           |
|                    |       |    |    |    |    |           |
|                    |       |    |    |    |    |           |
|                    |       |    |    |    |    |           |



**Longest Distance Sheet:**

| TEAM | Longest Distance |               |    | SCORE |
|------|------------------|---------------|----|-------|
|      | #1               | ATTEMPT<br>#2 | #3 |       |
|      |                  |               |    |       |
|      |                  |               |    |       |
|      |                  |               |    |       |
|      |                  |               |    |       |
|      |                  |               |    |       |
|      |                  |               |    |       |
|      |                  |               |    |       |
|      |                  |               |    |       |
|      |                  |               |    |       |
|      |                  |               |    |       |
|      |                  |               |    |       |
|      |                  |               |    |       |
|      |                  |               |    |       |
|      |                  |               |    |       |
|      |                  |               |    |       |
|      |                  |               |    |       |
|      |                  |               |    |       |
|      |                  |               |    |       |
|      |                  |               |    |       |
|      |                  |               |    |       |
|      |                  |               |    |       |
|      |                  |               |    |       |
|      |                  |               |    |       |
|      |                  |               |    |       |
|      |                  |               |    |       |

---



**Safety:**

- Make sure no students are in the catapult's trajectory before triggering it.

**Acknowledgments:**

- Future Scientists and Engineers of America, [www.fsea.org](http://www.fsea.org)

